

Preparation

Part Number: PT392-35100

Kit Contents

Item #	Quantity Reqd.	Description
1	1	Linkage Assembly
2	1	Mounting Bracket
3	1	Spacer Plate
4	1	Step Pad
5	1	Hardware Bag

Hardware Bag Contents

Item #	Quantity Reqd.	Description
1	2	M10 Hex Bolt
2	2	Washer
3	3	1/4-20 x 1" SHCS
4	3	1/4-20 Nut Plate

Additional Items Required For Installation

Item #	Quantity Reqd.	Description
1		

Conflicts

Accessory Hitch (Factory Hitch okay)
Resin Bumper

Recommended Tools

Personal & Vehicle Protection	Notes
Safety Glasses	
Special Tools	Notes
Table Vice	Must open at least 3"
Installation Tools	Notes
Ratchet Wrench	
6" Extension	
17mm Socket	
3/16 Allen Wrench	
Torque Wrench	0-100 lbf-ft
Special Chemicals	Notes

General Applicability

Tacoma (MY 2010 -) (only fits models with Factory Receiver Hitch)
--

Recommended Sequence of Application

Item #	Accessory
1	

*Mandatory

NOTE: Part number of this accessory may not be the same as the part number shown.

Vehicle Service Parts (may be required for reassembly)

Item #	Quantity Reqd.	Description
1		
2		
3		

Legend

 **STOP:** Damage to the vehicle may occur. Do not proceed until process has been complied with.

 **OPERATOR SAFETY:** Use caution to avoid risk of injury.

 **CAUTION:** A process that must be carefully observed in order to reduce the risk of damage to the accessory/vehicle and to ensure a quality installation.

 **TOOLS & EQUIPMENT:** Used in Figures calls out the specific tools and equipment recommended for this process.

 **REVISION MARK:** This mark highlights a change in installation with respect to previous issue.

 **SAFETY TORQUE:** This mark indicates that torque is related to safety.

Care must be taken when installing this accessory to ensure damage does not occur to the vehicle. The installation of this accessory should follow approved guidelines to ensure a quality installation.

These guidelines can be found in the "Accessory Installation Practices" document.

This document covers such items as:-

- Vehicle Protection (use of covers and blankets, cleaning chemicals, etc.).
- Safety (eye protection, rechecking torque procedure, etc.).
- Vehicle Disassembly/Reassembly (panel removal, part storage, etc.).
- Electrical Component Disassembly/Reassembly (battery disconnection, connector removal, etc.).

Please see your Toyota dealer for a copy of this document.

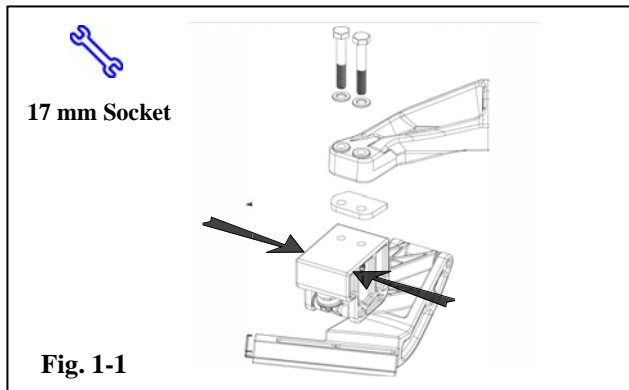

1. Assemble Linkage to Mounting Bracket.

- (a) With Linkage Assembly secure in vice at points indicated by the arrows, bolt Linkage Assembly to Mounting Bracket with spacer and torque Hex Bolts to 44N·m (33 ft-lbs) ± 4 N·m. (Fig. 1-1)



- (1) Keep Linkage Assembly in closed (or stowed) position.
- (2) Protect (cover) part with cloth when placed in vice for paint damage.

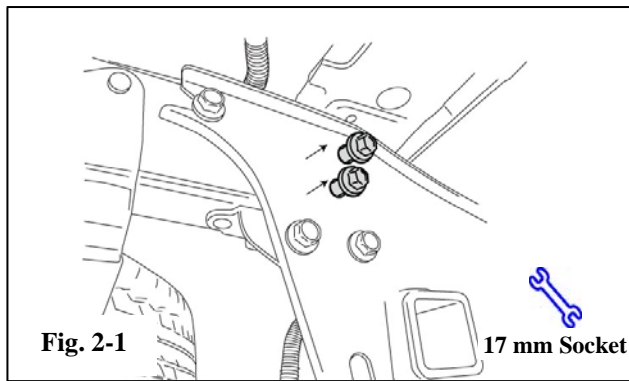

2. Locate and Prepare Mounting Point.

- (a) Locate rear bumper attachment point on driver side. (Fig. 2-1)
- (b) Remove two bumper fasteners with ratchet wrench and 17mm socket. (Fig. 2-1)

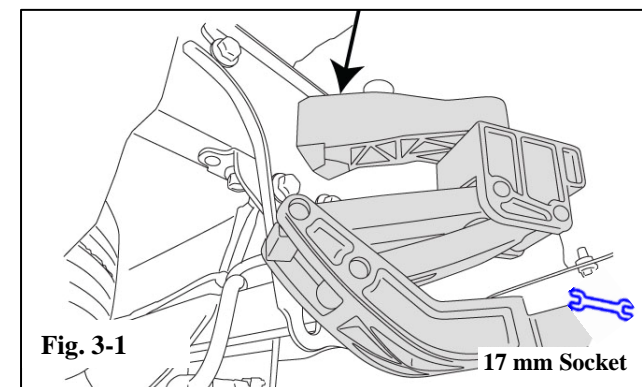

3. Install Bumper Step Assist to Mounting Point

- (a) Rotate Bumper Step Assist assembly into position and install mounting bracket using factory fasteners.



- (1) Keep linkage assembly in closed (or stowed) position. (Fig 3-1)



- (2) Torque fasteners to 90 N·m (66 ft-lbs) ± 15 N·m.

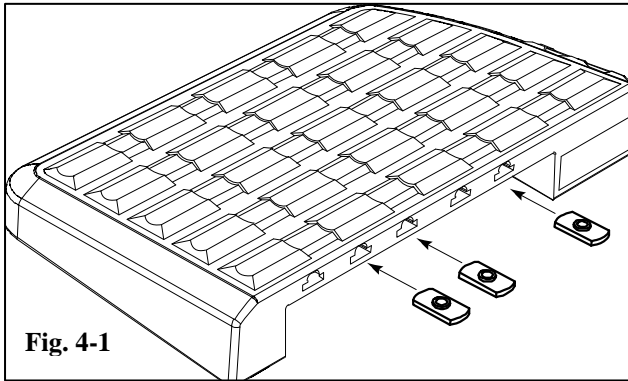

Fig. 4-1

4. Prepare for Step Pad Installation

- (a) Push Linkage Assembly into lowered position.
- (b) Insert three Nut Plates into designated slots. (Fig. 4-1)
 - (1) Raised lip of nut plate faces upward.
 - (2) Use second, third, and fifth slots only.

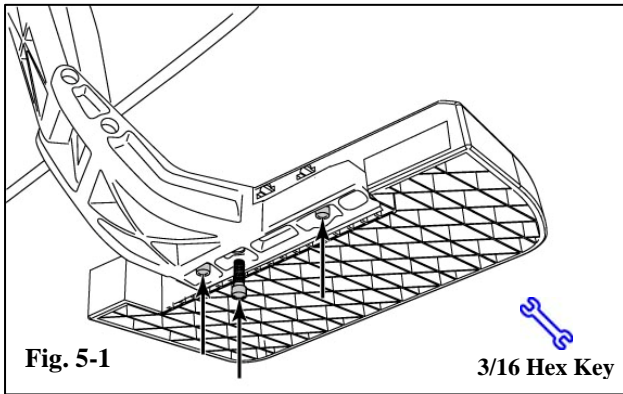

Fig. 5-1

3/16 Hex Key

5. Install Step Pad

- (a) Locate Step Pad onto mount of Linkage Assembly.
 - (1) Step Pad interface allows two positions... use position that extends step pad most inboard. (Fig. 5-1)
 - (2) This allows foot access for deploying step. (Fig. 5-2)
- (b) Insert cap screws into corresponding holes (second, third, and fifth) and torque to 8 N·m (6 ft-lbs) ±1.5 N·m. (Fig. 5-1)

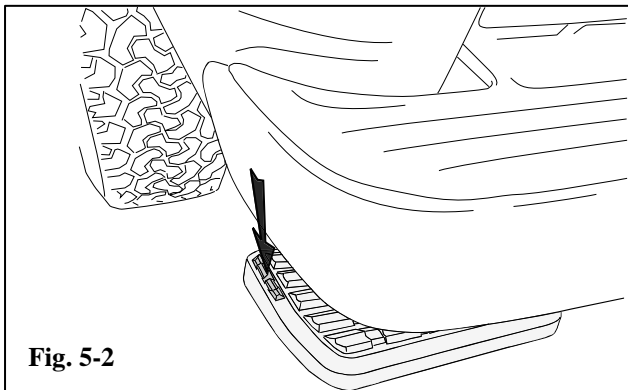

Fig. 5-2

TOYOTA TACOMA 2010 - BUMPER STEP ASSIST
 Checklist - these points **MUST** be checked to ensure a quality installation.

Check:	Look For:
<p><u>Accessory Function Checks</u></p> <ul style="list-style-type: none"> <input type="checkbox"/> Torque adjustment of bracket mounting bolts <input type="checkbox"/> Torque adjustment of bracket/linkage assembly bolts. <input type="checkbox"/> Step Pad Position <input type="checkbox"/> Torque adjustment of Step Pad screws <p> Process check: Auditor will confirm the torque wrench setting and observe the installer performing the process.</p> <p><u>Note:</u> The bolts may loosen 1ft-lb over the first 24 hour period. This is very common with plastic components and is commonly referred to as “creep” in the plastic industry. THIS IS NOT A SAFETY ISSUE.</p>	<p><u>Look For:</u></p> <p>Bracket mounting bolts must be tightened to 40-48 N·m (30-36 ft-lbs.)</p> <p>Bracket mounting bolts must be tightened to 75-105 N·m (55-77 ft-lbs.)</p> <p>Ensure foot access for deployment. Step deploys with downward force to left leading corner (indication by raised grip section).</p> <p>Step Pad screws must be tightened to 6.5-9.5 N·m (5-7 ft-lbs.)</p>